

# U50 FLAT PANEL MOUNT SPECIFICATION SHEET

**MAX TOTAL WEIGHT 200 LBS / 90.71 KG**

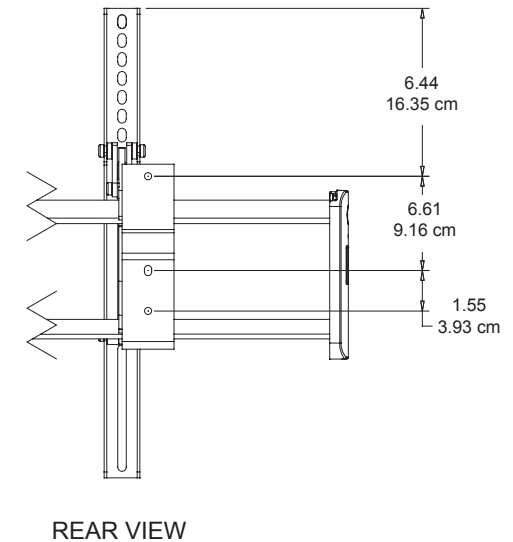
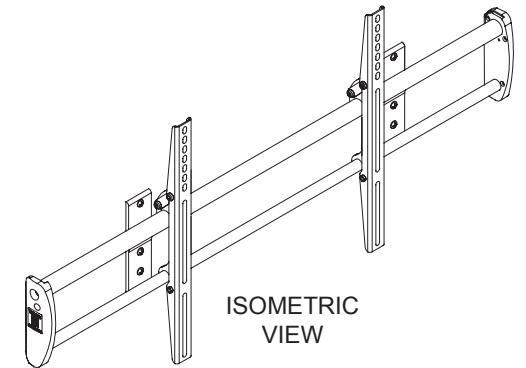
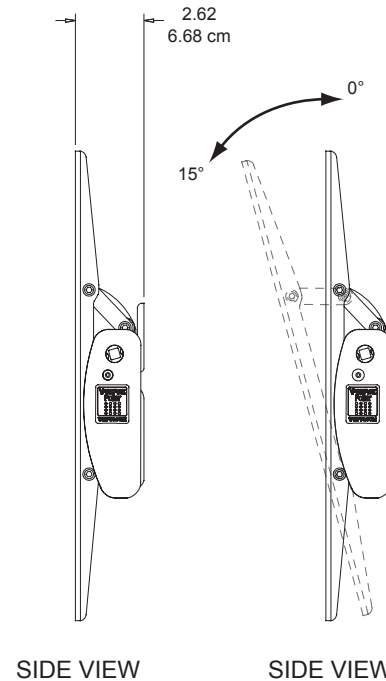
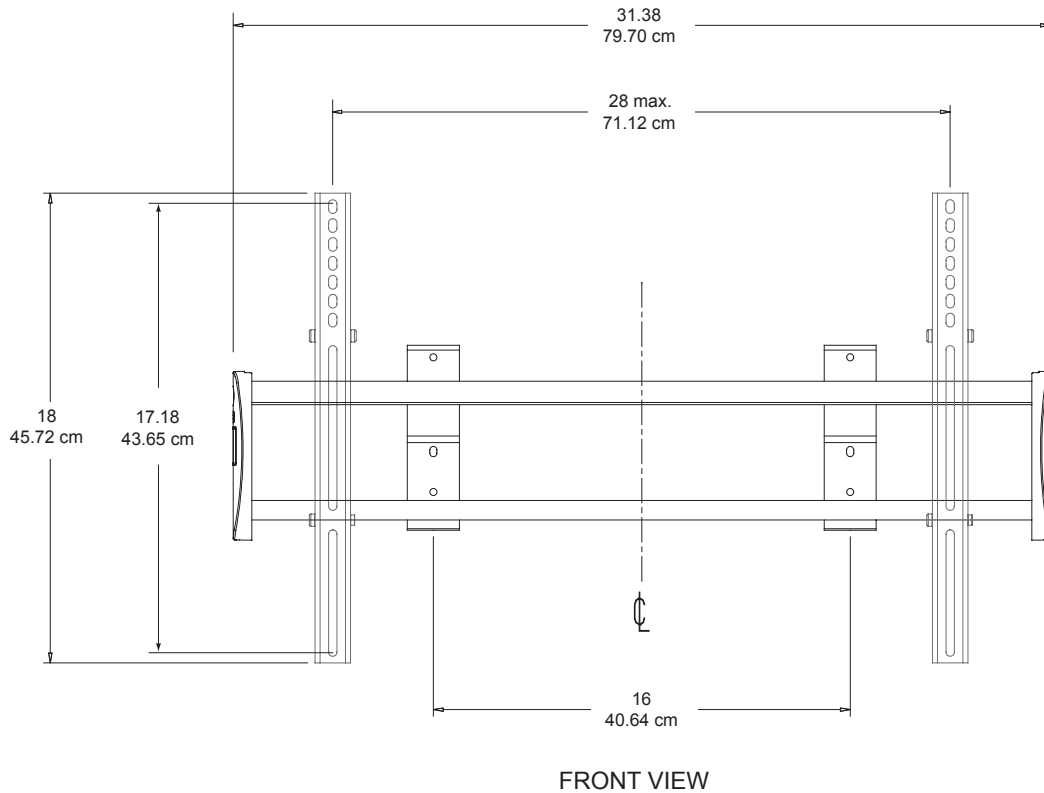

Vantage Point Products Corp. 10233 Palm Drive Santa Fe Springs, CA 90670  
USA: 800.582.9595 Canada: 905.607.9994 Europe: 31.72.581.6056  
Email: [cons-serv@vanptc.com](mailto:cons-serv@vanptc.com) Website: [www.vanptc.com](http://www.vanptc.com)